

# Tray Box Former

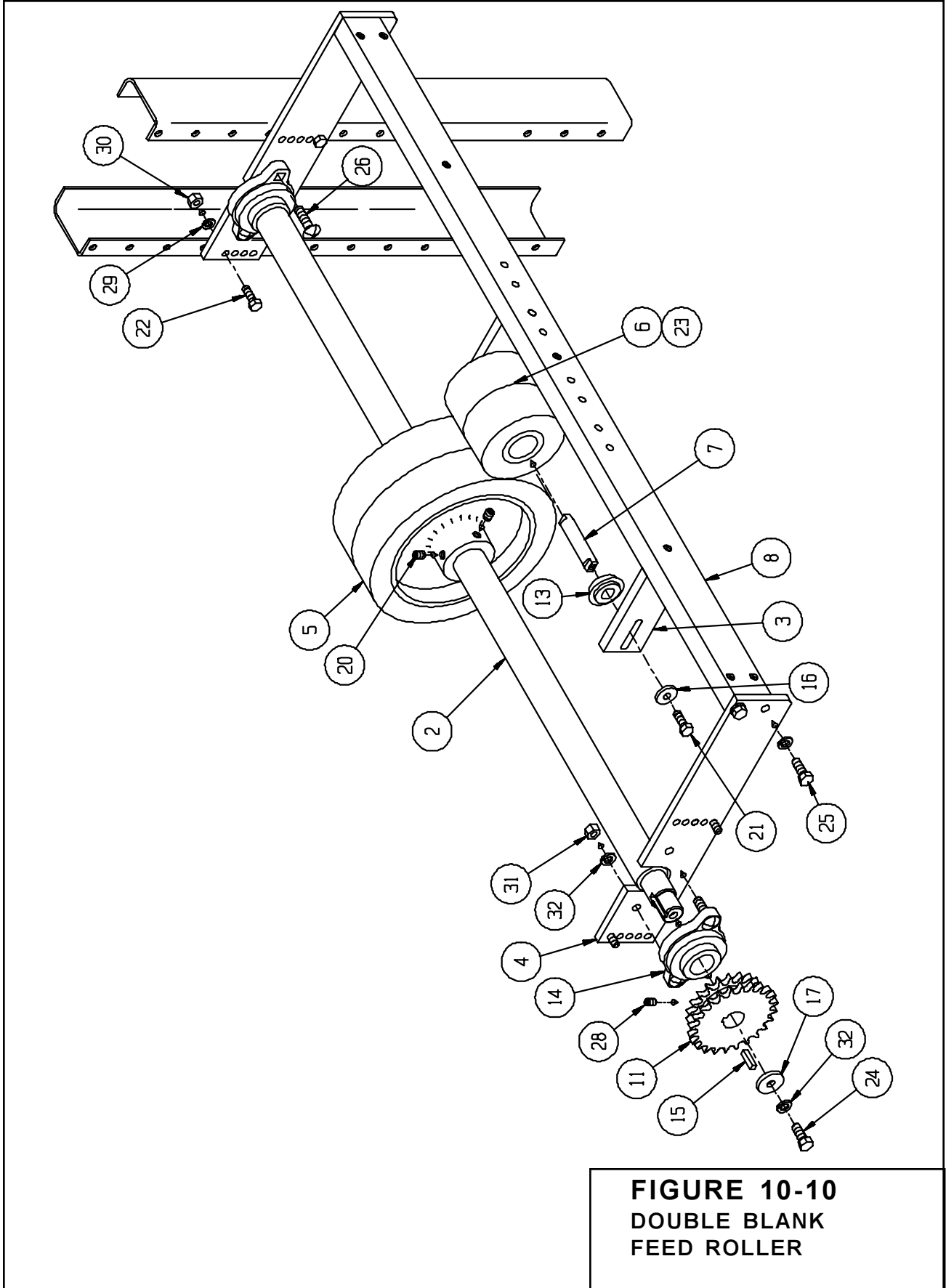

**FIGURE 10-10**  
**DOUBLE BLANK FEED ROLLER**

ITEM	PART NO.	DESCRIPTION	QTY.
2	0015205	SHAFT, BLANK FEED ROLLER	1
3	0016400	MOUNT, BLANK FEED IDLE ROLL	2
4	0017706	PLATE, BLANK FEED TRANS.	2
5	0018001	WHEEL, BLANK FEED	2
6	0018100	ROLLER, BLANK FEED IDLE	2
7	0018402	AXLE, BLANK FEED IDLE ROLL	1
8	0020504	BAR, BLANK FEED IDLE ROLL MT	1
11	0045400	SPROCKET, VACUUM FEED DRIVE	1
13	0500600	BRG., BLANK FEED IDLE ROLL	4
14	0501201	BRG., BLK FD IDLE ROLL DR SFT	2
15	0900301	KEY, 1/4 X 1/4 1 LG	1
16	1500102	WASHER	2
17	1500500	WASHER	1
20	8033700	3/8 NC X 1/2 SKT SET SCR	4
21	8008300	5/16 NC X 1 HEX HD SCR	2
22	8008300	5/16 NC X 1 HEX HD SCR	4
23	0205000	WASHER	1
24	8009900	3/8 NC X 3/4 HEX HD SCR	1
25	8010000	3/8 NC X 1 1/4 HEX HD SCR	4
26	8001500	3/8 NC X 1 3/4 CARRIAGE BOLT	4
28	8027000	5/16 NC X 1/2 C/P SKT SET SCR	2
29	8036700	5/16 LOCK WASHER	4
30	8024400	5/16 NC NUTS	4
31	8024500	3/8 NC NUTS	4
32	8036800	3/8 LOCK WASHER	8



# Tray Box Former



**FIGURE 10-10**  
DOUBLE BLANK  
FEED ROLLER

*Option Parts & Illustrations*